

S SERIES

사출 전용 회전형 다관절



한양로보틱스의
사출 전용 회전 다관절 로봇 S 시리즈는
초보자도 쉽고 간편하게 취출 및 자동화
작업이 가능합니다.



▲10.1in 대형 화면

Dimension | 외형치수 Unit : mm

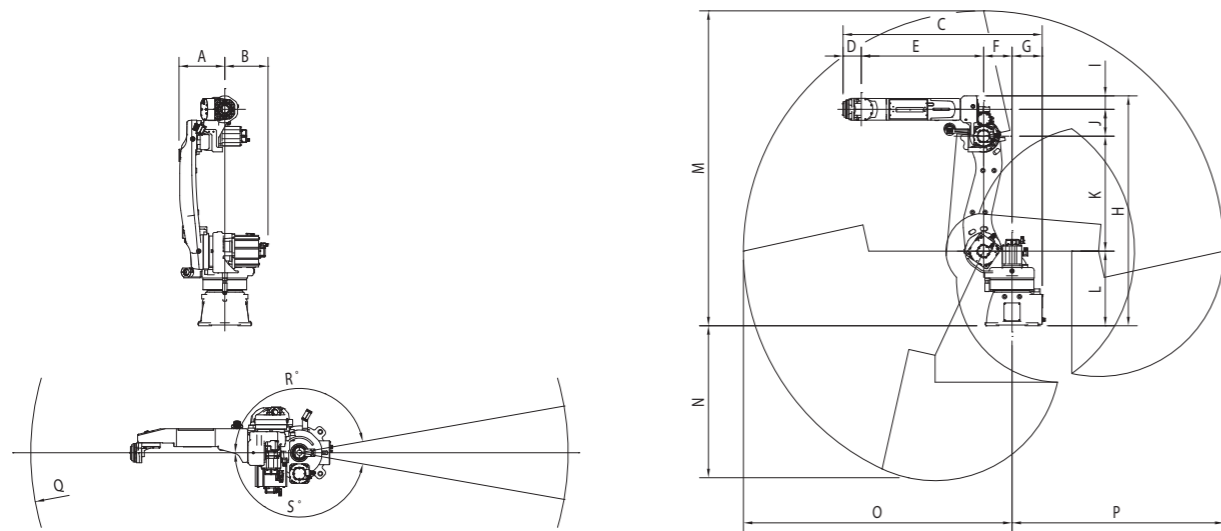

모델	A	B	C	D	E	F	G	H	I	J	K	L	M	N	O	P	Q	R	S
S6-1835	307	289	1334	122	820	190	202	1540	90	180	770	500	2110	1018	1800	1420	1800	170	170
S6-2035	307	299	1524	122	950	220	232	1637	90	180	820	547	2334	1146	2007	1787	2007	170	170
S6-3080	435	443	2239	215	1250	450	324	2323	193	230	1320	580	3171	1866	3041	1634	3041	170	170
S6-3480	443	448	2439	215	1450	450	324	2523	193	230	1520	580	3568	2248	3438	1954	3438	170	170

Technical Specification | 기술사양

Model	S6-1835	S6-2035	S6-3080	S6-3480
제어축수(Controlled axes)	6 axes (J1, J2, J3, J4, J5, J6)			
설치 방법(Installation Method)	바닥설치, 선반설치 Floor Mounted, Shelf Mounted			
리치(reach)	1800 mm	2007 mm	3041 mm	3438 mm
각 축별 동작 범위 (Motion Range of each shaft)	Joint 1	-170° ~ 170°	-170° ~ 170°	-170° ~ 170°
	Joint 2	-90° ~ 155°	-90° ~ 155°	-38° ~ 155°
	Joint 3	-180° ~ 85°	-180° ~ 85°	-180° ~ 80°
	Joint 4	-180° ~ 180°	-180° ~ 180°	-180° ~ 180°
	Joint 5	-180° ~ 180°	-180° ~ 180°	-180° ~ 180°
	Joint 6	-180° ~ 180°	-180° ~ 180°	-180° ~ 180°
각 축별 운동 속도 (Motion Velocity of each shaft)	Joint 1	208° /s	192° /s	124° /s
	Joint 2	263° /s	228° /s	228° /s
	Joint 3	259° /s	259° /s	179° /s
	Joint 4	372° /s	372° /s	217° /s
	Joint 5	368° /s	368° /s	257° /s
	Joint 6	522° /s	522° /s	316° /s
기구부 무게(Weight)(cable excluded)	285 kg	375 kg	1174 kg	1236 kg
가반하중(Maximum Load)	35 kg	35 kg	80 kg	80 kg
위치반복정밀도(Repeatability)	± 0.05 mm	± 0.05 mm	± 0.1 mm	± 0.2 mm
주변 온도(Ambient temperature)	0~40°C	0~40°C	0~40°C	0~40°C
IP code	IP65	IP65	IP65	IP65
최대소요전력(Max. electric Consumption)	10.25 kw	10.25 kw	20 kw	20 kw
전원사양(Power)	3상 AC380V(50/60Hz), 3Phase AC380V(50/60Hz)			